

VS Series

Vehicle Mounted Thom-Katt® Pumps



Putzmeister

VS Series

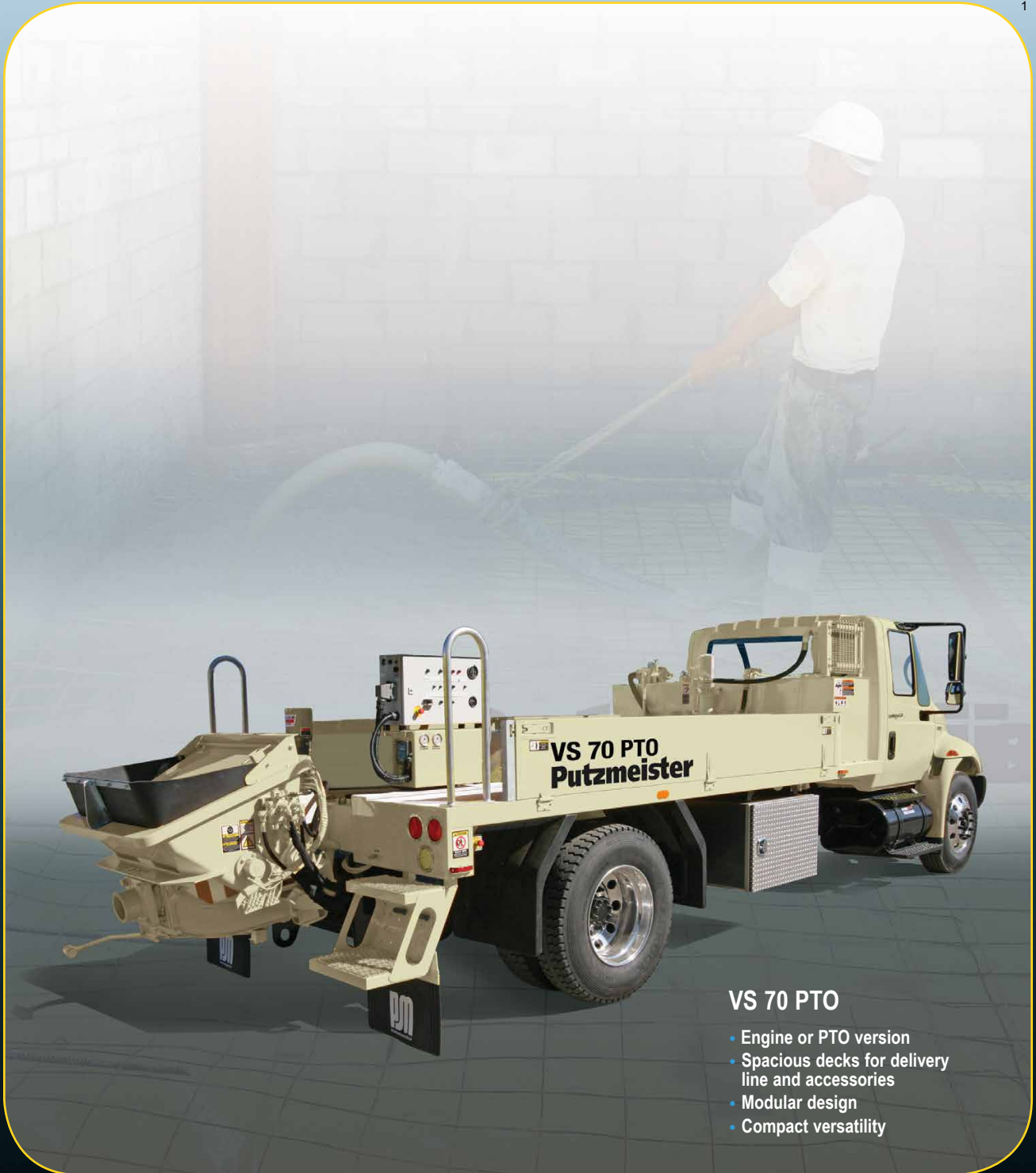

VS 70 PTO

- Engine or PTO version
- Spacious decks for delivery line and accessories
- Modular design
- Compact versatility

VS Series Specifications

Performance	VS 60 HP	VS 50	VS 70
Max volume output	60 yd ³ /hr (46m ³ /hr)	54 yd ³ /hr (41m ³ /hr)	74 yd ³ /hr (57m ³ /hr)
Max concrete pressure	1450 psi (100 bar)	1150 psi (79 bar)	1130 psi (78 bar)
Max aggregate size	1.5" (38mm)	1.5" (38mm)	1.5" (38mm)

Technical Information

Material cylinders	6" x 39" (150x1000mm)	6" x 39" (150x1000mm)	7" x 39" (180x1000mm)
Max strokes per minute	48	44	42
Main hydraulic pump	Rexroth	Rexroth	Rexroth
Variable volume control	0 to full	0 to full	0 to full
S-Valve (cast)	6" x 5" (150x125mm)	6" x 5" (150x125mm)	7" x 5" (180x125mm)
Hopper capacity	9.5 cu ft (270L)	9.5 cu ft (270L)	9.5 cu ft (270L)
Outlet diameter	5" HD (125mm)	5" HD (125mm)	5" HD (125mm)

Engine Version

Manufacturer's model	Deutz	Deutz	Deutz
(Water-cooled)	TCD2012L042V	TCD2012L04m	TCD2012L04m
Horsepower	131 hp (98kW)	100 hp (75kW)	100 hp (75kW)
Hydraulic tank capacity	35 US gal (132L)	35 US gal (132L)	35 US gal (132L)

PTO Version

Drive description	Engine only	PTO-Driven from truck engine through G61 distribution gearbox	
Hydraulic tank capacity	54 US gal (204L)	54 US gal (204L)	54 US gal (204L)

Maximum theoretical values listed. Note: Maximum output and pressure cannot be achieved simultaneously. Specifications subject to change without prior notice. Photos for illustrative purposes only. Refer to Putzmeister's operator manual for safe and proper equipment operation.

Truck Dimensions

Shown on GMC TT7500 chassis; other chassis available*

*Truck dimensions will vary with different truck makes, models and specifications.

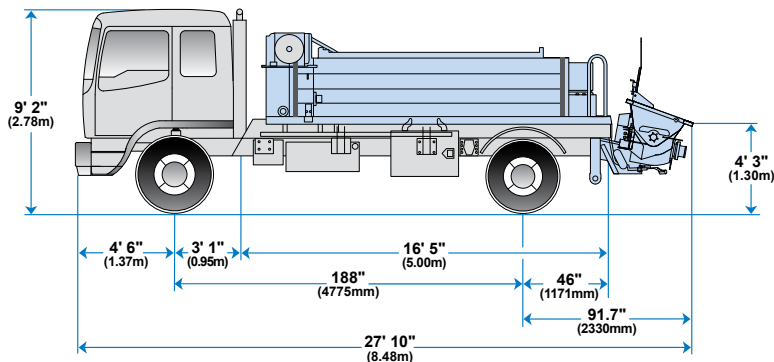

Model VS 70 PTO
Shown with optional deck-mounted pipe racks and fold-down side panels. Fixed side panels standard.

Chassis Ratings:
Front axle weight = 8,483 lbs (3,847kg)
Rear axle weight = 10,770 lbs (4,885kg)
Approx GVW = 19,253 lbs (8,732kg)

Standard Features

- Twin-shifting ball and socket cylinders
- High performance diesel engine or PTO drive
- Water temp gauge (engine models only)
- Engine cover (except PTO models)
- Variable displacement axial piston pump
- Long lasting fabric-reinforced piston cups
- Variable volume (0 to full) – pump output
- Double hydraulic circuit w/ accumulator
- Proximity sensors inside cylinders with Sure Stroke
- Hydraulic oil cooler
- Proven reliable S-Valve with splined shaft and centralized hopper-mounted grease ports
- Hard-chromed material cylinders
- Electric engine start/stop (engine models only)
- Harsh-mix 9.5 ft.3 (270L) hopper with hydraulic remixer
- Hopper grate
- Hopper cut-out device
- Splash guard with hopper bib
- Accessible heavy-duty hinged clean out hopper door
- Fully enclosed weatherproof control panel (NEMA rated)
- Emergency stop button with light
- Convenient stroke change switch
- Manual stroke change kit
- 3-function remote control - start, stop, reverse and E-stop - with 100 ft. (30m) cable
- High pressure water system with pump, tank and hose
- 175 gallon (660L) water tank
- Hour meter
- Tachometer - engine version only
- Large side decks with fixed side panels
- Entry steps to both deck sides
- Large side-mounted aluminum toolboxes
- High quality paint finish
- Ship-away kit with replacement filters

Options Consult factory for more options

- Deck-mounted pipe racks and fold-down side panels that accommodate 30 pipes 10' (3m) long (PTO version only)
- 3-function wireless remote control at 1000 ft. (305m) range – start, stop, reverse, E-stop
- 4-function wireless remote control at 1000 ft. (305m) range – start, stop, reverse, throttle, E-stop
- 5-function wireless remote control at 1000 ft. (305m) range – start, stop, reverse, throttle, volume, E-stop
- Automatic lubrication system w/timer
- Electric stroke counter



Putzmeister America, Inc. Telephone (262) 886-3200
1733 90th Street (800) 884-7210
Sturtevant, WI 53177 USA Facsimile (262) 884-6338
www.putzmeister.com



Authorized Distributor